

INSTALLATION INSTRUCTIONS

C-2300HV, Go/No Mini Split-Core Digital Output

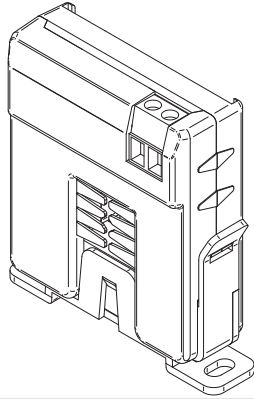

DANGER

Failure to follow these instructions will result in death or serious injury.



Hazard of electrical shock, explosion, and arc flash

- Follow ALL requirements in NFPA 70E for safe work practices and for Personal Protective Equipment (USA) and other applicable local codes when installing this product
- Only qualified electrical personnel should install this product.
- Read, understand, and follow all instructions thoroughly
- Install only on insulated conductors
- Lock out and tag out all power sources prior to installation. Use properly rated voltage sensing instrument to determine no voltage is present



WARNING

Failure to follow these instructions could result in death or serious injury.



Automated equipment may start without warning

- Equipment monitored/operated by this device may start without warning. Keep clear of apparatus at all times

IMPORTANT WARNINGS

- Only qualified trade installers should install this product
- This product is not intended for life-safety applications
- Do not install in hazardous or classified locations
- The installer is responsible for all applicable codes
- This product must be installed in a suitable electrical enclosure



INSTALLATION



Disconnect, lock out and tag out all power supplies during installation

1. Determine mounting location for the sensor near the conductor to be monitored. The sensor should be located AT LEAST 1/2" from any uninsulated conductor.
2. Sensor features a flexible iris which allows the sensor to hang on the conductor if local codes permit. A bracket is included for screw mounting or attaching to DIN rail. For screw mounting, drill two 3/32" pilot holes using the bracket as a template; ensure no drill shavings are present in enclosure. Attach bracket with screws provided.
3. Clamp sensor around INSULATED CONDUCTOR ONLY, 600VAC MAX to be monitored.
4. Snap the sensor into the mounting bracket.
5. Wire the output of the sensor in series with a contactor coil not to exceed 120VAC @ 0.2 Amp. Tighten terminals to 3.5 in-lb.

WIRING EXAMPLES

NOTE: Device is NOT polarity sensitive.

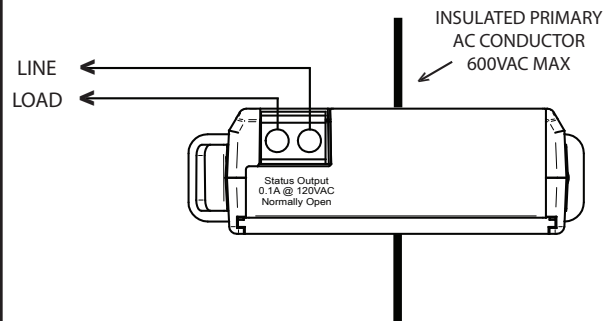

PRODUCT APPLICATION LIMITATION:

Senva products are not designed for life or safety applications. Senva products are not intended for use in critical applications such as nuclear facilities, human implantable device or life support. Senva is not liable, in whole or in part, for any claims or damages arising from such uses.



DIMENSIONS

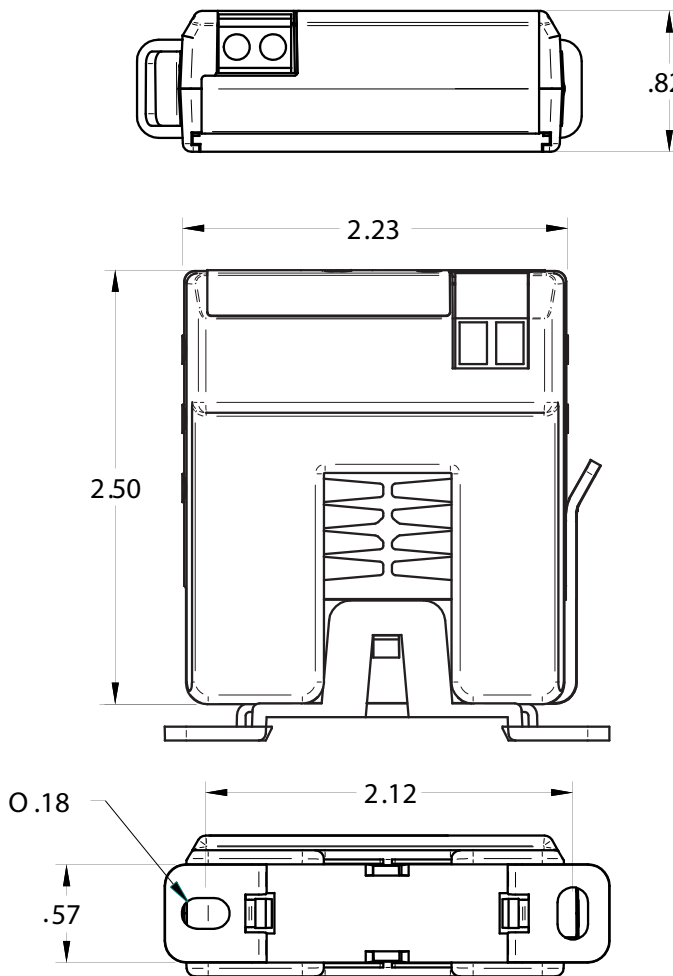

OPERATION

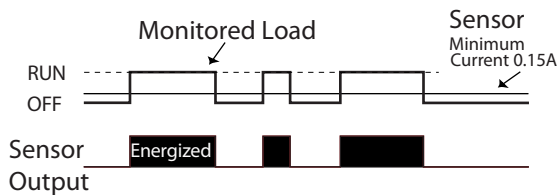

The C-2300HV output changes state whenever current above 0.15A is present. This provides "go/no" status on loads that are not subject to mechanical failures.

Typical on/off status applications include:

- Lighting circuits
- Heater elements
- Direct drive fans (e.g. exhaust fans)
- Process motors

TECH TIPS

On low current loads, wrap sensor multiple times to increase sensitivity

CAUTION: Do not exceed sensor maximum current. The current detected by the sensor will increase 1X with each wrap.

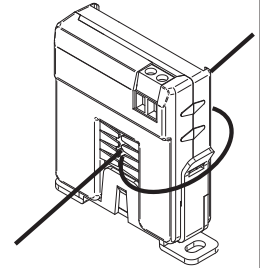

To monitor loads greater than the current sensor maximum rating

Use a properly rated 5A CT as shown below



CAUTION!

5A CTs can present hazardous voltages. Install CTs in accordance with manufacturers instructions. Terminate the CT secondary wiring before energizing primary conductor.

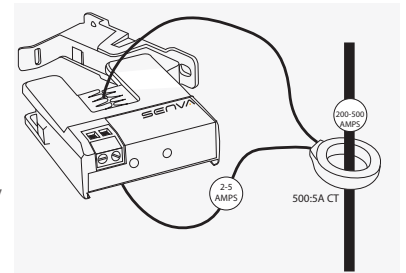

Troubleshooting

Symptom	Causes	Remedy
Sensor output does not change state	Amperage is below sensor minimum threshold	Wrap monitored conductor turns through sensor. See Tech Tip
	Testing with ohm meter yields incorrect results	Solid state output may show approx. 1 ohm or less.
	Incorrect control wiring	Ensure control loop voltage is present

Maximum surrounding air ambient, 60 ° C.

For use in Pollution Degree 2 Environment.

Part Number	C-2300HV
Amperage Range	0.35A (on)~100A (200A Max)
Output Type	NO, solid-state FET
Output Rating	0.2A (200mA) @120VAC Max
Temperature Rating	-15~60 ° C
Insulation Class	600V RMS. For use on insulated conductors only! Use minimum 75 ° C insulated conductor
Sensor Power	Induced
Frequency Range	50/60Hz
Dimensions (LxWxH)	2.94" x 2.23" x 0.82" (1.4" H with optional relay module)
Sensor Aperture	0.75"